

valid for 380 V - 415 V / 50 Hz

load capacity	2000 kg	travelling speed	5 / 20 m/min
FEM group	4m / M7	lifting speed	0.8 / 5 m/min
hook path	6000 mm	trolley span	300 mm

**drives**

	<b>hoist motor</b>	<b>travel drive (2 drives)</b>
performance	motor type L 0.28 / 1.9 kW	trolley E 100 0.03 / 0.12 kW
duty cycle	60 %	50 %
no. of switching operations	360 c/h	300 c/h
nominal speed	410 / 2800 1/min	640 / 2670 1/min
rated current	1.8 / 5 A	0.29 / 0.46 A
starting current	2.9 / 22 A	0.4 / 1.2 A
cos phi <sub>N</sub>	0.6 / 0.83	0.67 / 0.85
cos phi <sub>A</sub>	0.73 / 0.8	0.85 / 0.94

ED (c/h) values represent the sum of the values for precision and main lifting  
These are divided up into 1/3 (2/3) operation with precision and 2/3 (1/3) operation with main speed

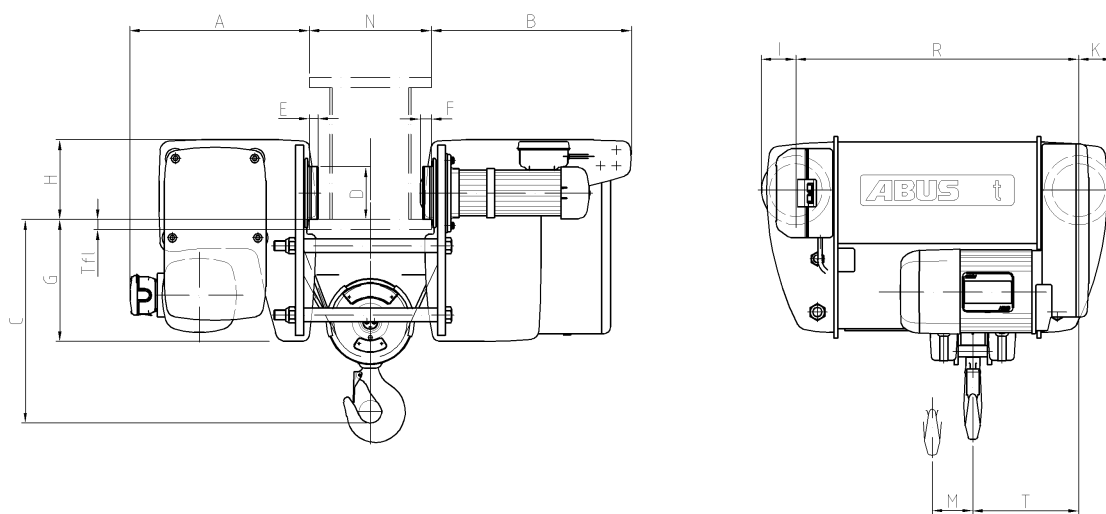

**dimensions and weights**

rope diameter	6.5 mm	A	391 mm	I	70 mm
cable length	29150 mm	B	474 mm	K	70 mm
drum diameter	176 mm	C	400 mm	M	76 mm
rope pulley diameter	162.5 mm	D	100 mm	N <sub>min</sub>	98 mm
weight of bottom block	15.0 kg	E	20 mm	N <sub>max</sub>	400 mm
load hook (E)	1.0 - V	F	25 mm	R	594 mm
radius of curves	≥ 5300 mm	G	280 mm	T	216 mm
weight	242 kg	H	176 mm	T <sub>fl</sub>	30 mm
trolley span	300 mm				

Wheels suitable to be used on parallel flanges; wheels for inclined flanges upon request  
When using a trolley travel limit switch dimension H will increase by 55 mm  
Dimension C with bigger load hooks and track N > 300 mm on request  
Smaller tracks upon request

**load data for the track according to DIN 4132**

<b>load case H</b>			<b>load case HZ</b>		<b>load case HS</b>
R <sub>max</sub> <sup>1)</sup> / wheel	RKA <sub>min</sub> <sup>2)</sup> / wheel	RKA <sub>mit</sub> <sup>3)</sup> / wheel	FSKA <sup>4)</sup> / hoist	FMKA <sup>5)</sup> / hoist	FPUKR <sup>6)</sup> / hoist
6.83 kN	0.59 kN	5.50 kN	1.10 kN	0.36 kN	6.2 kN

<sup>1)</sup> Wheel load with highest hook position without coefficient  
<sup>2)</sup> Wheel load under dead weight without coefficient  
<sup>3)</sup> Wheel load with mean hook position without coefficient

<sup>4)</sup> Loads transverse to the runway (hoist)  
<sup>5)</sup> Loads along the runway (hoist)  
<sup>6)</sup> Buffer force valid when using ABUS buffers (hoist)

ABUS Kransysteme GmbH Sonnenweg 1 51647 Gummersbach	<b>monorail trolley with wire rope hoist</b> GM 800.2000 L-204.41.6000.4.E 100.20	15/04/2010
---	--	------------